

# Guideline to Core and Sample Handling at GEUS

Niels H. Schovsbo, Rikke Weibel, Julie Christina Steen,  
Carsten M. Nielsen

# **Guideline to Core and Sample Handling at GEUS**

Niels H. Schovsbo, Rikke Weibel, Julie Christina Steen,  
Carsten M. Nielsen

## **Table of Contents**

Table of Contents	2
1. Introduction and Scope	3
2. GEUS Reference Framework	5
3. General Principles for Sample Handling	6
4. Core Slabbing and Inspection Sections	7
7. Sidewall Cores and Drill Cuttings	15
8. Delivery of Material to the GEUS Core Store	16
9. Operator Checklist for Delivery	21
References	22

## 1. Introduction and Scope

These GEUS guidelines on core handling, preservation, transport, and storage are prepared in accordance with the *Executive Order on Submission of Samples and Other Information about the Danish Subsoil* and the *Guidelines for Drilling and Well Operations Onshore Denmark (2024)* issued by the Danish Energy Agency (DEA).

These guidelines refer to the Danish Subsoil Act (Consolidated Act No. 1461 of 29 November 2023) with reference to the § 34 Executive Order (Executive Order No. 543 of 22 May 2025).

Pursuant to the Subsoil Act and associated executive orders, license holders are required to submit physical samples and related information obtained during subsurface activities to the Danish Energy Agency and the Geological Survey of Denmark and Greenland (GEUS). GEUS is responsible for the long-term storage, documentation, and management of physical samples in support of national subsurface knowledge and future use.

**These GEUS guidelines provide a technical elaboration of, and practical guidance for compliance with, the requirements set out by the Danish Energy Agency regarding submission of samples and subsurface information.**

Document versions and updates

These guidelines are issued both as a fixed report and as a continuously updated online version.

The fixed version is published as *GEUS Rapport 2026/11*.

The online version is available at [GEUS](#) Corestore website, and may be updated periodically to reflect new experience, regulatory changes, or technical developments.

Users of these guidelines are responsible for ensuring that they are working with the most recent version. The latest version shall always be accessed via the online link.

All versions are time-stamped to ensure traceability.

**Communication and questions are to be sent to [Corestore@geus.dk](mailto:Corestore@geus.dk) or [Geus@geus.dk](mailto:Geus@geus.dk).**

The purpose of the present GEUS guidelines is to:

- clarify expectations related specifically to core material, sidewall cores, drill cuttings, and formation fluids,
- support operators in planning drilling, sampling, preservation, and logistics activities,
- ensure that material delivered to GEUS is suitable for long-term archiving and future scientific and regulatory use.

These guidelines supplement the DEA's regulatory framework and do not replace operator obligations under applicable legislation.

The guidelines apply to material acquired during onshore drilling activities in Denmark, including exploration, appraisal and production wells for geothermal energy, CO<sub>2</sub> storage (CCS), hydrogen, compressed air, and any other subsurface uses covered by the Subsoil Act.

GEUS' role is to receive, curate, and archive material in a condition that preserves its physical and chemical integrity over decades. Detailed planning and execution of drilling, sampling, preservation techniques, and transport arrangements remain the responsibility of the operator.

## **2. GEUS Reference Framework**

GEUS' approach to sample handling and preservation is aligned with *Core Analysis – A Best Practice Guide* (McPhee et al., 2015), which provides internationally recognised best practices for the collection, handling, preservation, and documentation of core material.

GEUS' recommendations further build on Danish Energy Agency guidelines for drilling, well operations, and submission of subsurface samples, with emphasis on long-term archiving and re-use.

### **3. General Principles for Sample Handling**

All subsurface samples shall be handled in a manner that:

- ensures correct depth and orientation labelling,
- preserves physical integrity and original fabric,
- minimises drying, oxidation, and mechanical damage,
- ensures suitability for long-term storage and future re-analysis,
- allows visual inspection and representative sampling without unnecessary destruction.

Sample handling procedures shall be planned as part of the drilling and sampling programme submitted to the Danish Energy Agency.

## 4. Core Slabbing and Inspection Sections

After recovery and initial on-site documentation, full-diameter cores shall be slabbed in accordance with established good industry practice and with due regard to the objectives of long-term archiving and future re-use.

GEUS recommends that full-diameter cores are cut into **one-metre-long sections** prior to slabbing, unless otherwise technically justified. Each section shall be clearly and permanently marked to indicate orientation.

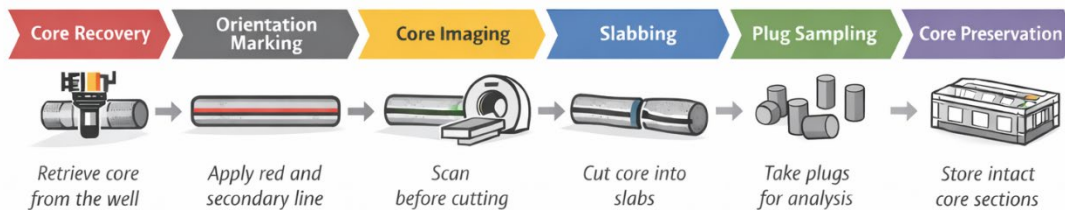

**Figure 1** Workflow schematics.

### 4.1 Orientation Marking

Core orientation shall be indicated by continuous longitudinal colour markings applied along the full length of each core section.

One reference line shall always be marked in red. When the core is oriented “up” (top depth facing upwards), the red line shall be positioned on the right-hand side of a second longitudinal line applied to distinguish orientation. By default, this line should be black. However, an alternative colour may be used where required to ensure sufficient visual contrast, for example in dark lithologies such as organic-rich shales.

In such cases, the selected colour shall:

- be clearly distinguishable from the red line,
- provide strong visual contrast under typical handling and storage conditions, and
- be used consistently for all core sections within the same well or project.

The selected colour scheme shall be documented as part of the core handling and metadata records.

Orientation markings shall be maintained throughout all stages of handling, including slabbing, preservation, packaging, and transport.

## 4.2 Core Imaging

Imaging methods may be selected and applied by the operator; however, procedures shall ensure that imaging does not alter or damage the core material. If applied non-destructive core imaging (e.g. photography, CT scanning, or other scanning methods) should be carried out at an early stage of the workflow, prior to slabbing, plug sampling, or other core-consuming procedures.

## 4.3 Slabbing Procedure and Layout

Slabbing shall, where feasible, be carried out after completion of core imaging and documentation (see Section 4.2).

Slabbing of core sections shall be planned and executed to ensure both:

- preservation of a representative, permanent inspection surface, and
- retention of sufficient material for subsequent sampling and laboratory analyses.

### Order of operations (slabbing vs. plug sampling)

As a general principle, slabbing should be carried out prior to plug sampling in order to ensure optimal preservation of the inspection slab and consistent documentation of core fabric.

However, where core material is weakly consolidated, fractured, or otherwise sensitive to handling (e.g. mudstones or poorly lithified sandstones), plug sampling may be carried out prior to slabbing. In such cases, preservation of representative plug material and data quality shall take priority.

The selected approach shall be documented.

### Slabbing geometry and core division

Slabbing shall be performed as an eccentric longitudinal cut, producing:

- one continuous inspection slab (archive slab; section B in Figure 2), and
- one or more remaining core fractions (working sections; section A and, where relevant, C in Figure 2).

The inspection slab shall be continuous, representative of the full core interval, and permanently mounted (e.g. epoxy-bonded in trays) suitable for long-term archiving, visual inspection, and non-destructive analysis.

The relative size of the inspection slab and working section(s) shall be adapted to core diameter and anticipated analytical requirements, with the objective of preserving sufficient material for plug sampling after slabbing.

As general guidance:

- For core diameters (D) below approximately 3 inches (typical research wells or deep sections), slabbing is generally not recommended due to limited remaining material for analysis.
- For core diameters (D) in the range of approximately 3–4 inches (typical in an 8.5-inch hole), a slabbing configuration corresponding to approximately one-third of the diameter ( $1/3 \times D$ ) for the inspection slab B plus slab C and two-thirds of the diameter ( $2/3 \times D$ ) for the working section (A) is typically appropriate.
- For core diameters (D) of approximately 5 inches (typical in a 12.25-inch hole) and above, a larger working section (up to approximately three-quarters of the core diameter ( $3/4 \times D$ ) for A slab) may be considered, provided that a representative inspection slab (B) is maintained.

The final slabbing configuration shall ensure that:

- both 1.5 inch horizontal and vertical plug samples can be obtained where required, and
- sufficient material remains for future analyses after initial sampling.

Any deviations from these general principles shall be technically justified and documented.

## Longitudinal slabbing of core

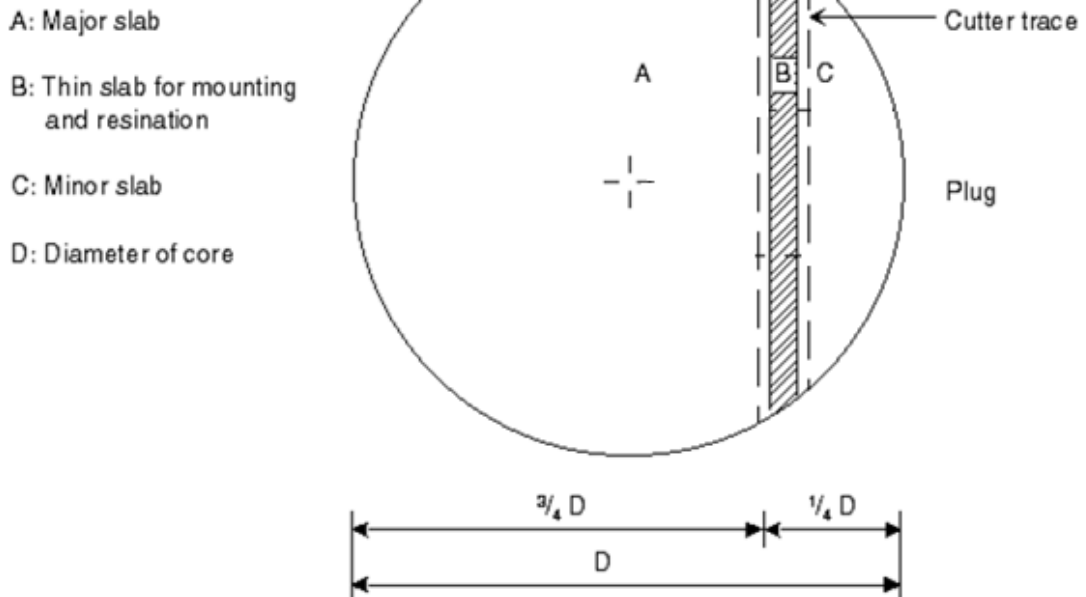

**Figure 2** The recommended slabbing and preservation layout, ensuring that a permanent visual reference of the core is preserved even if remaining core material is later sampled or consumed. Note that the cut ratio between A and B+C vary with core diameter. Here shown for a core diameter between 3-4 inch.

## 5. Core Preservation – General Requirements

The purpose of preserved core sections is to maintain selected intervals in a condition as close as possible to in-situ physical and chemical conditions, suitable for long-term storage and future re-analysis.

GEUS requires that **at least 10% of the total recovered core length** shall be preserved as intact whole-core sections, unless otherwise agreed. This requirement reflects the general principles outlined in Section 3, in particular the need to ensure suitability for long-term storage and future re-analysis.

Preserved sections shall be representative of key lithologies, facies, and intervals of interest. Where project objectives or geological conditions justify it (e.g. sealing formations or intervals of special analytical interest), a larger proportion of the core should be preserved.

Preserved sections shall be clearly documented and listed upon delivery, and preservation shall be carried out as early as possible after core recovery, i.e. prior to plug sampling and other core-consuming procedures such as slabbing, where feasible.

### 5.1 Plug Sampling

Plug sampling shall be designed to provide representative petrophysical data while minimising sampling bias. Sampling strategies shall be adapted to lithological variability, project objectives, and available geological information.

Plug orientation shall, where feasible, be defined relative to bedding rather than core axis. As a general principle:

- plug samples shall primarily be taken parallel to bedding, and
- plug samples perpendicular to bedding shall also be included in order to characterise anisotropy.

Where relevant, additional plug orientations (e.g. oblique to bedding) may be considered for advanced characterisation of directional properties.

Sampling shall be carried out in a systematic manner to ensure representative coverage of the core and to reduce bias. Both interval-based sampling (e.g. fixed spacing) and geology-driven sampling (e.g. based on lithological units or prior non-destructive core logging) may be appropriate.

As a general reference, a simple interval-based sampling strategy may consist of approximately 3–4 plugs per metre of core, primarily oriented parallel to bedding and supplemented by fewer plugs perpendicular to bedding to characterise anisotropy. This frequency is intended to provide a balance between data resolution and preservation of core material.

Standard plug diameters are typically 1 inch or 1½ inch. Where feasible, preservation of larger-diameter plugs (e.g. 1½ inch) is recommended, as these may provide increased flexibility for future analytical methods.

Where relevant, drilled but unused plugs shall be preserved (e.g. wax sealed) to minimise drying, oxidation, or fluid loss.

All plug locations, orientations (relative to bedding where possible), dimensions, preservation status, and preparation steps shall be clearly documented.

## 6. Special Considerations for Saline Aquifers Projects

For cores and derived samples from saline aquifers projects, additional considerations apply due to the high salinity of formation brines and the sensitivity of pore-scale properties.

Inspection slab preparation shall take into account potential salt precipitation and redistribution during drying. Preparation procedures should minimise artificial salt growth on slab surfaces that could obscure primary textures or fractures. Where technically justified, controlled removal of excess salts under carefully controlled conditions should be considered prior to embedding. Any such preparation steps shall be documented.

For saline aquifer-related cores, GEUS specifically recommends **wax sealing (wax impregnation)** of intact preserved core sections, as this method effectively limits evaporation and preserves pore fluids over long storage periods.

### 6.1 Plugging Fluids and Cleaning

Plugging fluids and cleaning procedures shall be selected to minimise alteration of the rock properties, including pore structure, wettability, and mechanical integrity, while ensuring stable and reproducible sample conditions for analysis and long-term storage.

For mudrocks and clay-bearing sandstones, plugging fluids shall be chosen to minimise clay swelling and chemical incompatibility. Where formation water composition is known, brine or synthetic formation water is recommended. Where formation water composition is unknown or incompatibility is expected, oil (e.g. depolarised kerosene, base oil, or mineral oil) should be used.

Cleaning of plug samples shall, as a general principle, be carried out using the least aggressive method compatible with the intended analysis. Cleaning procedures should include removal of salts and brine to reduce the risk of precipitation, redistribution, and storage-related artefacts.

**Low-temperature cleaning methods are preferred in order to minimise alteration of the rock matrix.**

The selection of cleaning method shall take into account the nature of the contaminants present. Non-polar solvents (e.g. toluene) are effective for removal of hydrocarbons and oil-based drilling fluids, whereas polar solvents (e.g. methanol) are required for removal of salts and water-soluble components.

Use of more aggressive cleaning methods (e.g. involving toluene or elevated temperatures) may be justified where required to remove drilling fluids or other contaminants. Such use shall be based on documented need.

Justification for more aggressive cleaning may include:

- knowledge of drilling fluid type (e.g. oil-based mud),
- evidence of significant mud or contaminant invasion (e.g. from CT imaging or visual inspection), or
- preliminary testing indicating that less aggressive methods are insufficient.

Where feasible, an initial assessment using a limited number of samples is recommended to guide the selection of cleaning method for the full sample set.

All cleaning procedures, including solvents used, temperatures applied, and any deviations from standard approaches, shall be clearly documented.

## 7. Sidewall Cores and Drill Cuttings

### 7.1 Sidewall Cores

Sidewall cores (percussion or rotary) are subject to the same submission requirements as other core material under the Danish Energy Agency guidelines. They shall be clearly identified by depth and orientation (where available), packaged in airtight and mechanically robust containers, and documented using the same principles as full cores.

Remaining sidewall core material after analysis shall be returned to GEUS as soon as practicable, in compliance with the one-year deadline set out in § 15(2) of the § 34 Executive Order, unless otherwise agreed.

### 7.2 Drill Cuttings

Drill cuttings shall be collected and submitted in accordance with the requirements set out by the Danish Energy Agency.

In accordance with these requirements, **two cuttings fractions shall be collected and submitted:**

1. **Washed and dried cuttings**, where drilling mud and fines have been removed, intended primarily for lithological description and stratigraphic interpretation.
2. **Unwashed (wet) cuttings**, retained without washing, preserving drilling mud, fines, and adhered material for potential future analytical use.

Both fractions **shall be sampled at the same depth intervals as the cuttings collected for the license holder's own use.**

As part of good practice, GEUS expects that:

- sufficient sample volumes are retained to allow geological description and long-term reference, (usually wet cuttings ca 500 g, washed and dried cuttings ca 50 – 100 g)
- washed and unwashed fractions are clearly distinguished,
- all samples are clearly labelled with borehole ID, depth interval, sampling date, and fraction type.

The applied washing, drying, and handling procedures shall be documented.

GEUS notes that cuttings provide a complementary dataset to core material; however, cores remain the primary archive material.

## 8. Delivery of Material to the GEUS Core Store

This section defines operator responsibilities related to packaging, documentation, transport, and delivery of core material, cuttings, and associated well samples in compliance with the one-year deadline set out in § 15(2) of the § 34 Executive Order, unless otherwise agreed.

### 8.1 Packaging, Core Length, and Pallet Compatibility

The GEUS Core Store uses standard European pallets (1.20 × 0.80 m). To ensure compatibility with storage systems and allow for potential expansion of certain lithologies during drying, GEUS recommends that core boxes do not exceed **1.10 m in length**.

Core boxes shall:

- fit securely on EUR-pallets,
- be stackable in a stable manner,
- protect material against mechanical damage during transport and storage.

Core material shall not be placed tightly against box ends, as certain lithologies (e.g. clay-rich cores) may expand slightly during drying.

### 8.2 Use of Original Core Boxes

Where cores are delivered in packaging compatible with EUR-pallet dimensions and stacked in a stable manner, GEUS accepts storage in original core boxes or packaging. Repacking will only be undertaken where strictly necessary.

### 8.3 Formation and Production Fluids

Liquid samples (brine, formation water, test fluids) shall be transported under **cooled conditions**, typically **4–8 °C**, unless otherwise technically justified. Cooled transport is intended to limit chemical alteration, reduce biological activity, and preserve dissolved components prior to analysis and archiving.

Samples shall be packed in tight, chemically compatible containers with secure closure and appropriate secondary containment.

As a standard reference solution (unless otherwise agreed), GEUS recommends submitting:

- Two 1-litre samples
- In tight, chemically compatible, wide-mouth containers (e.g. HDPE)
- With secondary containment
- With durable labelling including:
  - Well ID
  - Depth or test interval
  - Date/time
  - Test type
  - Reason for sampling

Basic fluid metadata (test conditions, sampling method, and relevant chemical information if available) shall accompany the delivery.

#### 8.4 Gas/pressurised samples

Gas samples and other pressurised samples shall be handled and transported in accordance with applicable safety and dangerous goods regulations.

The operator is responsible for:

- compliance with ADR and relevant transport legislation,
- use of approved pressure-rated containers,
- appropriate labelling and hazard identification.

Prior to shipment, the operator shall coordinate with GEUS regarding:

- sample type,
- container specification,
- expected pressure and composition,
- storage requirements.

Where technically feasible, duplicate samples are recommended.

GEUS reserves the right to decline receipt of pressurised samples that do not comply with safety requirements.

## 8.5 Cuttings Samples

Drill cuttings shall be collected and submitted in accordance with the requirements set out by the Danish Energy Agency.

In accordance with these requirements:

### **Two cuttings fractions shall be collected and submitted:**

- Washed and dried cuttings
- Unwashed (wet) cuttings

Both fractions shall be sampled at the same depth intervals as the cuttings collected for the license holder's own use.

GEUS expects that:

- sufficient sample volumes are retained to allow geological description and long-term reference,
- washed and unwashed fractions are clearly distinguished,
- samples are clearly labelled with well ID, depth interval, sampling date, and fraction type.

The applied washing, drying, and handling procedures shall be documented.

Cuttings shall be packaged to prevent cross-contamination, moisture loss (for wet samples), and mechanical loss of material during transport.

## 8.6 Drilling Fluid (Mud) Samples

In exploratory drilling, drilling fluid samples shall be taken from the inlet side of the active mud system:

- whenever a qualitative change in additives occurs,
- prior to production testing,
- and at least for every 300 m drilled.

Sample quantities and packaging shall be aligned with GEUS beforehand.

As a standard reference solution (unless otherwise agreed), GEUS recommends submitting:

- Two 1-litre sub-samples
- In tight, chemically compatible, wide-mouth containers (e.g. HDPE)
- With secondary containment
- Clearly labelled with:
  - Well ID
  - Depth (or drilled depth at time of sampling)
  - Date/time
  - Mud type (e.g. WBM, OBM)
  - “Inlet side”
  - Reason for sampling (300 m interval or additive change)

Basic mud metadata (mud type and additive information) shall accompany the delivery.

Drilling fluid samples are normally transported at ambient temperature unless otherwise agreed.

#### 8.7 Prepared Samples (Thin Sections, Slides, Polished Sections, Plugs, etc.)

**Prepared samples derived from core or cuttings (e.g. thin sections, polished sections, grain mounts, SEM stubs, CT-derived materials) shall be submitted where required under applicable regulations or agreed with GEUS.**

Such samples shall:

- be clearly labelled with well ID, depth, and sample ID,
- be accompanied by preparation documentation,
- include information on laboratory, preparation method, and orientation (where relevant).

Prepared samples shall be packed to prevent breakage, abrasion, or surface damage.

## 8.8 Documentation and Metadata Requirements

Operators shall provide a complete inventory of submitted material, including:

- core inventory (depths, recovery, box numbers),
- preserved core sections,
- plug sampling records,
- cleaning procedures,
- cuttings processing description,
- fluid and mud sampling records,
- analyses performed.

Documentation shall include methods applied, laboratories involved, and unique sample identifiers.

## 9. Operator Checklist for Delivery

Operators shall confirm compliance with the following prior to delivery:

1. Pre-delivery documentation completed.
2. Appropriate packaging and labelling applied.
3. Preserved core sections identified and listed.
4. Core length and pallet compatibility ensured.
5. Required cuttings fractions (washed/dried and wet) identified and labelled.
6. Fluid samples packaged and cooled as required.
7. Mud samples collected and documented in accordance with regulatory requirements.
8. Gas/pressurised samples compliant with transport regulations.
9. Transport arranged using qualified carriers.
10. Delivery coordinated with GEUS and receipt acknowledged. Contact to GEUS CoreStore: [corestore@geus.dk](mailto:corestore@geus.dk)

## References

McPhee, C., Reed, J., Zubizarreta, I. 2015. Core Analyses, A Best Practice Guide. Developments in Petroleum Science, Elsevier, 829 p.